



**POPOLNOMA NOVI**

**R**

**A**

**V**

**4**

**16. 4. 2026**

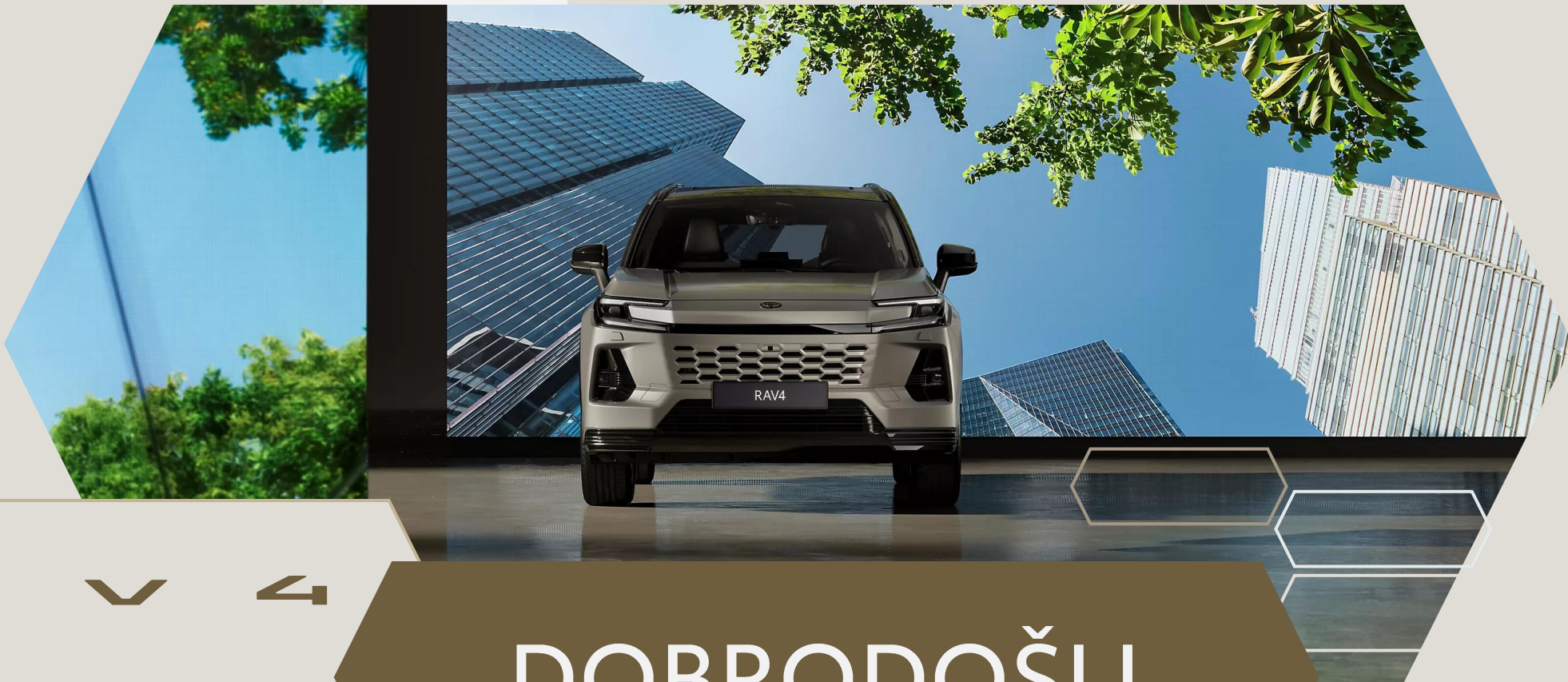

**RAV4**

**DOBRODOŠLI**



PREGLED TRGA

PRODUKTNA  
PREDSTAVITEV

TESTNE VOŽNJE

TOUCH AND  
FEEL

ČASOVNICA

# TOYOTA V SLOVENIJI #4



- 4. MESTO PO REGISTRACIJAH IN 6% TRŽNI DELEŽ
- 3. MESTO PO REGISTRACIJAH IN 8,8% TRŽNI DELEŽ MED FIZIČNIMI KUPCI
- 9. MESTO PO REGISTRACIJAH IN 3,5% TRŽNI DELEŽ MED POSLOVNIMI KUPCI



# Q1 ZA TOYOTO ODLIČNO



## CC ACCTUALS (N MONTH - MONTHLY PACE)

● 2025 ● 2026

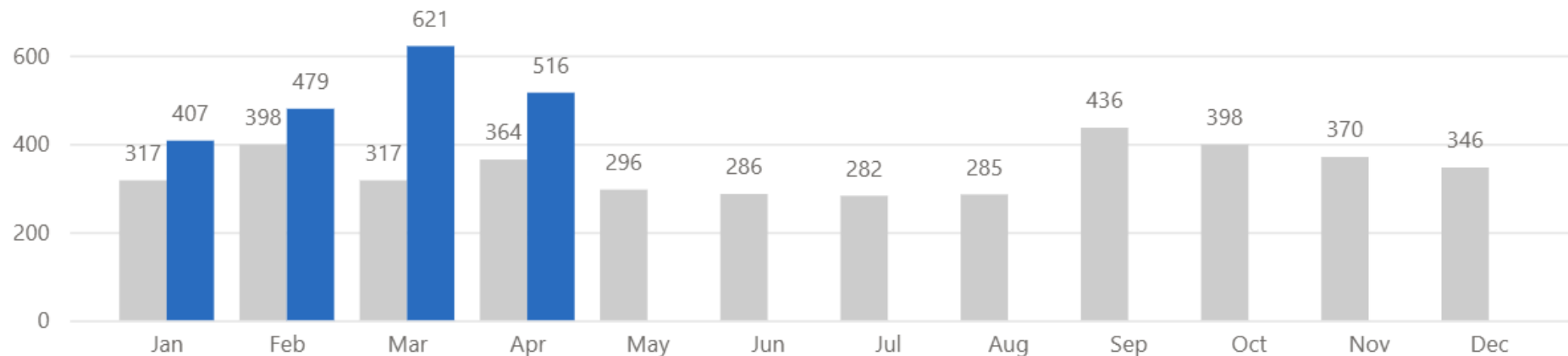

## RTL SALES ACCTUALS (N MONTH - MONTHLY PACE)

● 2025 ● 2026

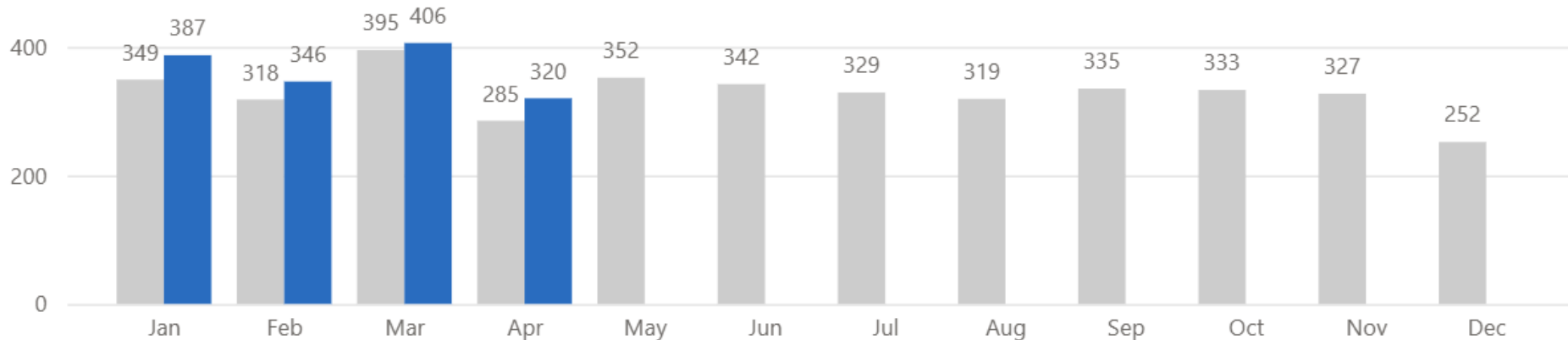

# GIBANJE SEGMENTOV V SLOVENIJI



- SUV segment v konstantni rasti
- B-SUV NAJVEČJI SEGMENT
  - YARIS CROSS
- C-SUV STALNICA NA 2. MESTU
  - COROLLA CROSS, C-HR IN C-HR+
- D-SUV NA 3. MESTU
  - Novi RAV4, BZ4X IN BZ4X TOURING



TRŽNI DELEŽ PO SEGMENTIH

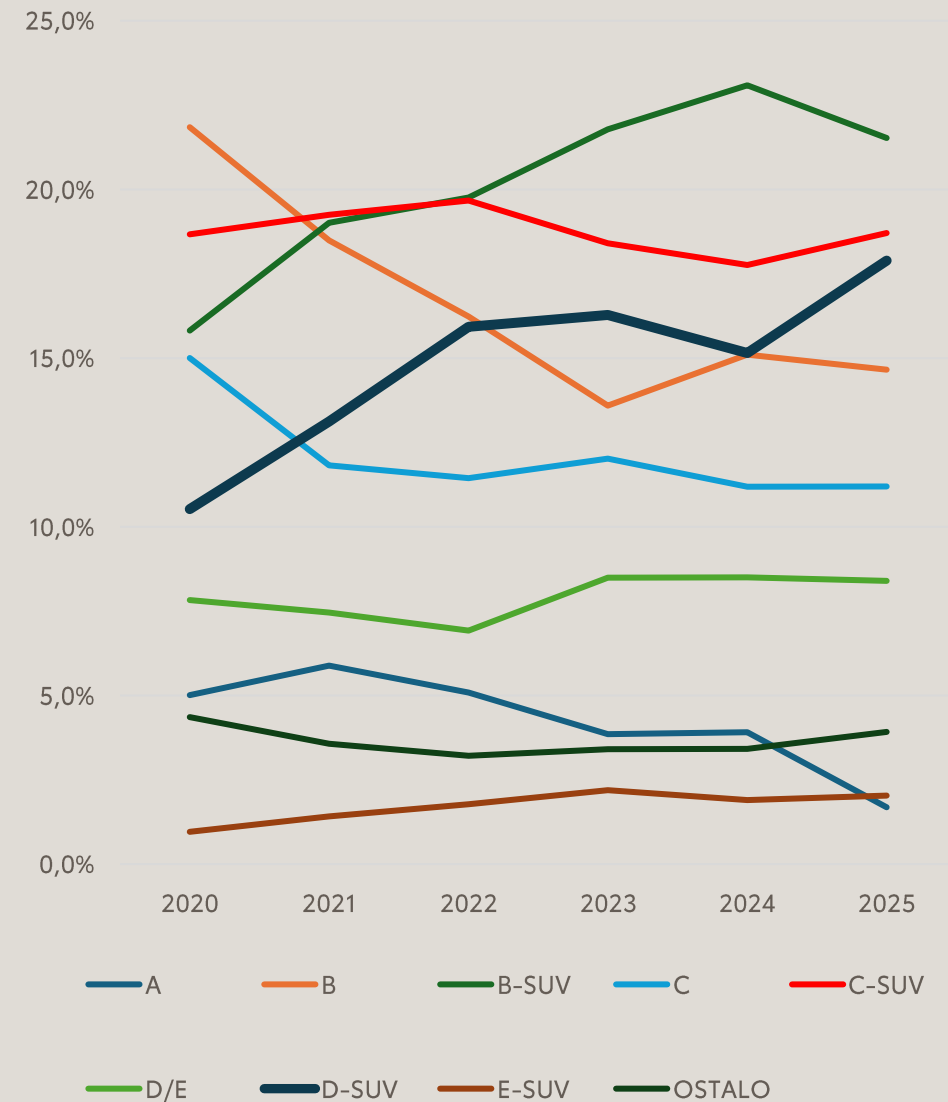



# TOYOTIN NAJBOLJE PRODAJANI SUV V EVROPI IN PO SVETU

## PRODAJA RAV4 PRETEKLIH GENERACIJ



Evropa



Po vsem svetu

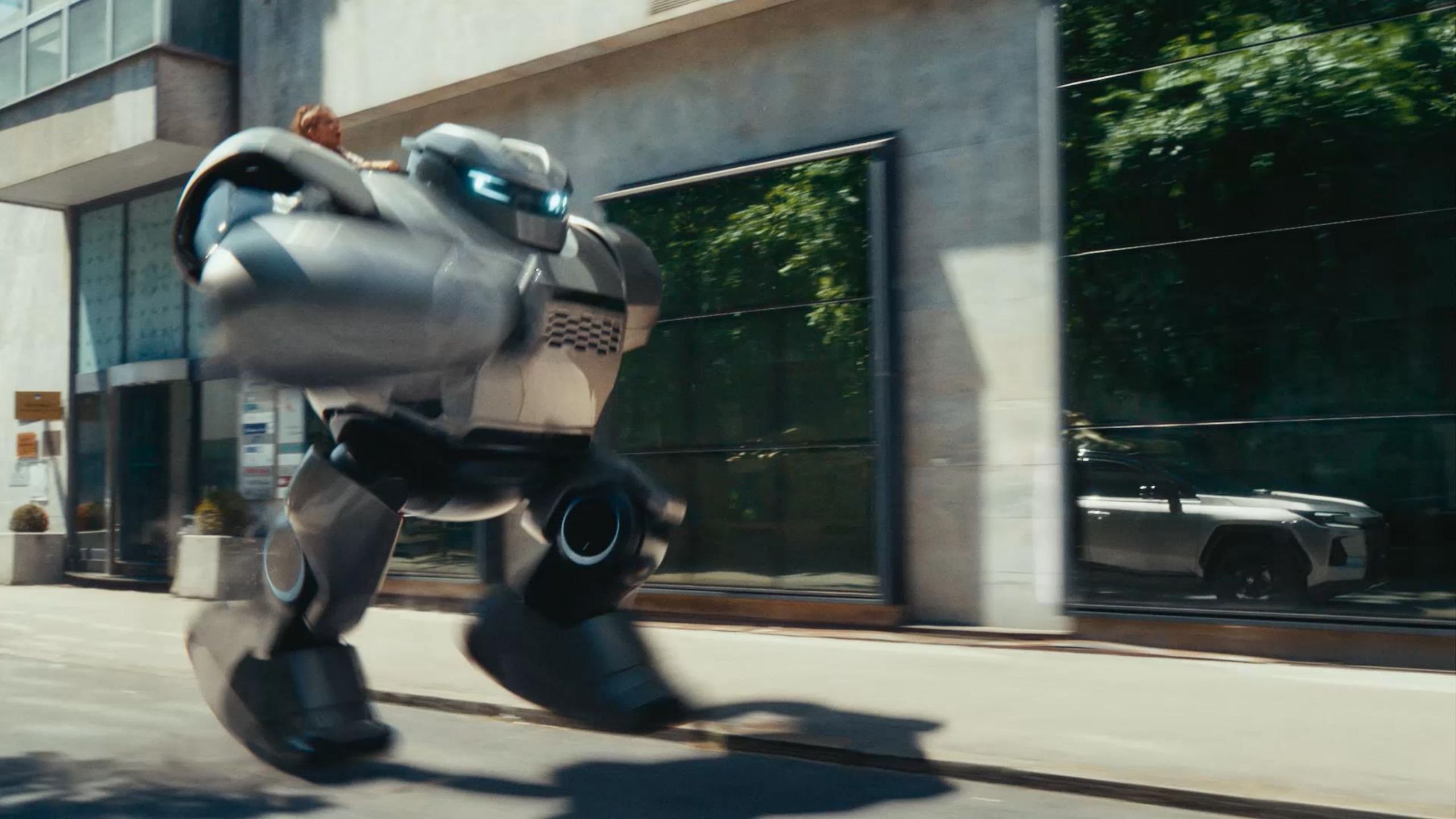



# GRADIMO NA VEČ KOT 30-LETNI DEDIŠČINI POSTAVLJANJE STANDARDOV V SEGMENTU

## 2001

Druga generacija



## 2013

Četrta generacija



## 2026

Šesta generacija



## 1994

Prva generacija

## 2006

Tretja generacija

## 2019

Peta generacija



ZUNANJOST

# ROBUSTEN IN AVTENTIČEN



**PODPIS**

## HAMMERHEAD SPREDAJ

Izraz 'kladvenice', ki ga sestavlja celoten sprednji del, ustvarja trden in dominantni videz Toyotinega vodilnega športnega terenca na cesti.



# FUNKCIONALNA LEPOTA

## SPREDNJA MREŽA

3D šesterkotni motiv vsebuje skrite kamere in senzorje za sisteme T-MATE.





## FUNKCIONALNA LEPOTA OHIŠJE MEGLENK



Združuje senzorje, aerodinamične plavuti in meglenke v enem samem črnem elementu, ki poudarja SUV-jevski značaj RAV4.



# EDINSTVEN SVETLOBNI PODPIS

## »OBVIJAJOČI« LED-ŽAROMETI

Integrirane funkcionalne komponente  
ustvarjajo tridimenzionalni svetlobni podpis.



# IZJEMEN SVETLOBNI PODPIS LED-ŽAROMETI IN ZADNJE LUČI



STYLE  
PREMIUM  
GR SPORT



ELEGANT



ZADNJA LUČ

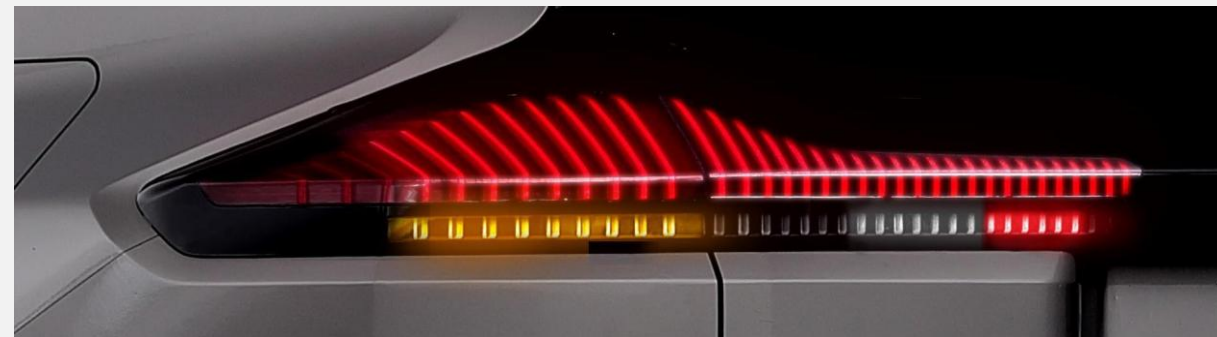

MAT ČRN

TOYOTIN EMBLEM



# ATLETSKI PROPORCI DINAMIČNA SILHUETA

Robustne terenske lastnosti in prava identiteta RAV4

Tekoče površine ob straneh ustvarjajo drzen, izklesan videz, ki poudarja moč in prefinjenost





UDARNO

20"

LITA PLATIŠČA

- ✓ Natančnejši občutek krmiljenja
- ✓ Zmanjšano nagibanje karoserije pri zavijanju
- ✓ Boljša stabilnost pri visokih hitrostih
- ✓ 18-palčna na nivoju opreme Elegant



# ZNAČAJ SUV-JA

## IZRAZITI ZADNJI KOLESNI LOKI



Varna drža odraža stabilnost in moč  
– na cesti in izven nje.



PRISTEN STIL SUV-JA  
NOVA ZNAČKA RAV4



# BARVNA PALETA



**NOVO**



1M6 WARM STONE

**NOVO**



6X7 FOREST GREEN

**NOVO**



1L6 URBAN SHADE



040 PURE WHITE



089 PLATINUM PEARL WHITE

**NOVO**



4V8 AVANTGARDE BRONZE



218 ATTITUDE BLACK



3T3 TOKYO RED



8X8 TEMNO MODRA



**RAV4**

**PROSTORNOST, UDOBJE IN  
VSEBNOST SUV-JA**

# FILOZOFIJA NOTRANJOSTI

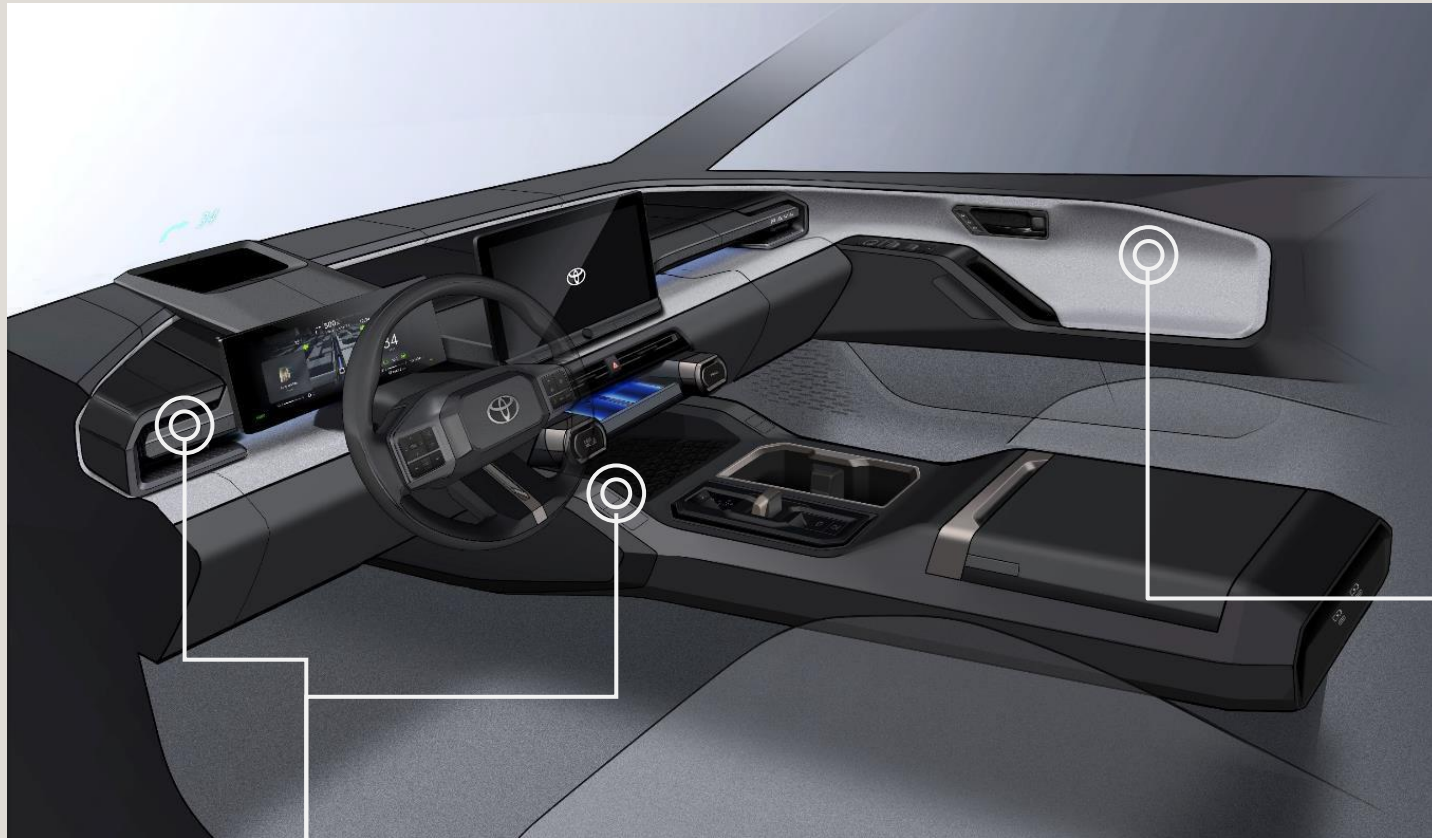

## OTOŠKA ARHITEKTURA

Ključne funkcije so združene in poudarjene za dostopnost



## OBČUTEK DNEVNE SOBE

Osebno prostorsko vzdušje, ustvarjeno z oblogami, barvami in teksturami



# OPTIMALNA VIDLJIVOST INSTRUMENTNA PLOŠČA

– 40 mm

nižje od predhodnega modela





**NOV VOLAN**  
**+1 CM GLOBINE**  
**+1 CM VIŠINE**



# OPTIMALNA ERGONOMIJA NOVA PRESTAVNA ROČICA



Parkirno stikalo

2 stopnji naprej: R

1 stopnja naprej: N

1 stopnja nazaj: D

2 stopnji nazaj: S pri modelih z obvolanskima prestavnima ročicama

2 stopnji nazaj: B pri modelih HEV brez obvolanskih prestavnih ročic

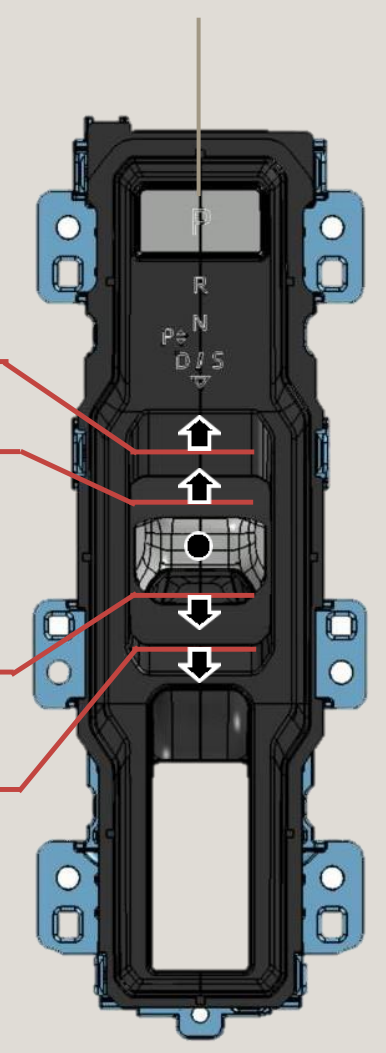

# NOVA STIKALA ZA IZBOR POGONA



## HEV

**Načini vožnje:**  
NORMAL/ECO/SPORT

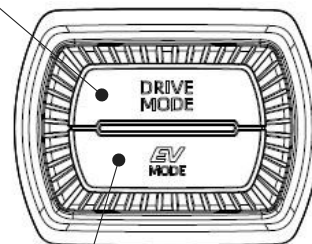

**Način pogona HEV:**  
Način EV vklopi vožnjo EV

## PHEV

**Načini vožnje:**  
NORMAL/ECO/SPORT

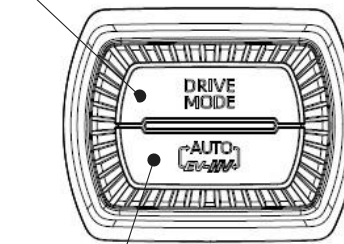

**Načini pogona PHEV:**

- Način EV
- Samodejni način EV/HV
- Način HV



# NOVA STIKALA ZA IZBOR POGONA

## ZMOGLJIVOST VOŽNJE PO VSEH CESTAH

### AWD (HEV in PHEV)

#### Način TRAIL

Ohranjanje oprijema na grobih  
ali neravnih cestah

#### Način SNEG

Upravljanje pri speljevanju in  
vožnji po spolzkih površinah

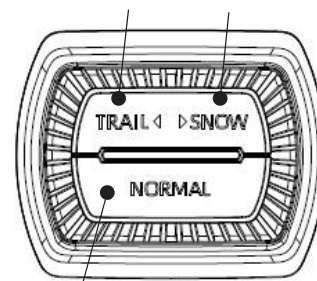

#### NORMALNI način:

Vrnitev v normalne cestne  
razmere

### FWD (HEV in PHEV)

#### AUTO LSD:

Vklop/izklop načina AUTO LSD  
in nadzora stabilnosti vozila  
(VSC)

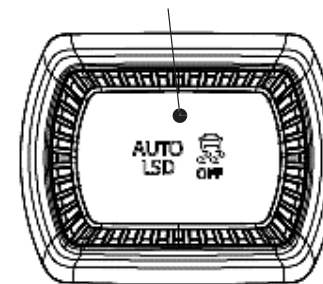



**PROSTOR IN UDOBJE V SUV-JU**  
**PROSTOR ZA POTNIKE SPREDAJ**

# UDOBJE NA VSEH CESTAH

## PROSTOR ZA POTNIKE

### SPREDNJE

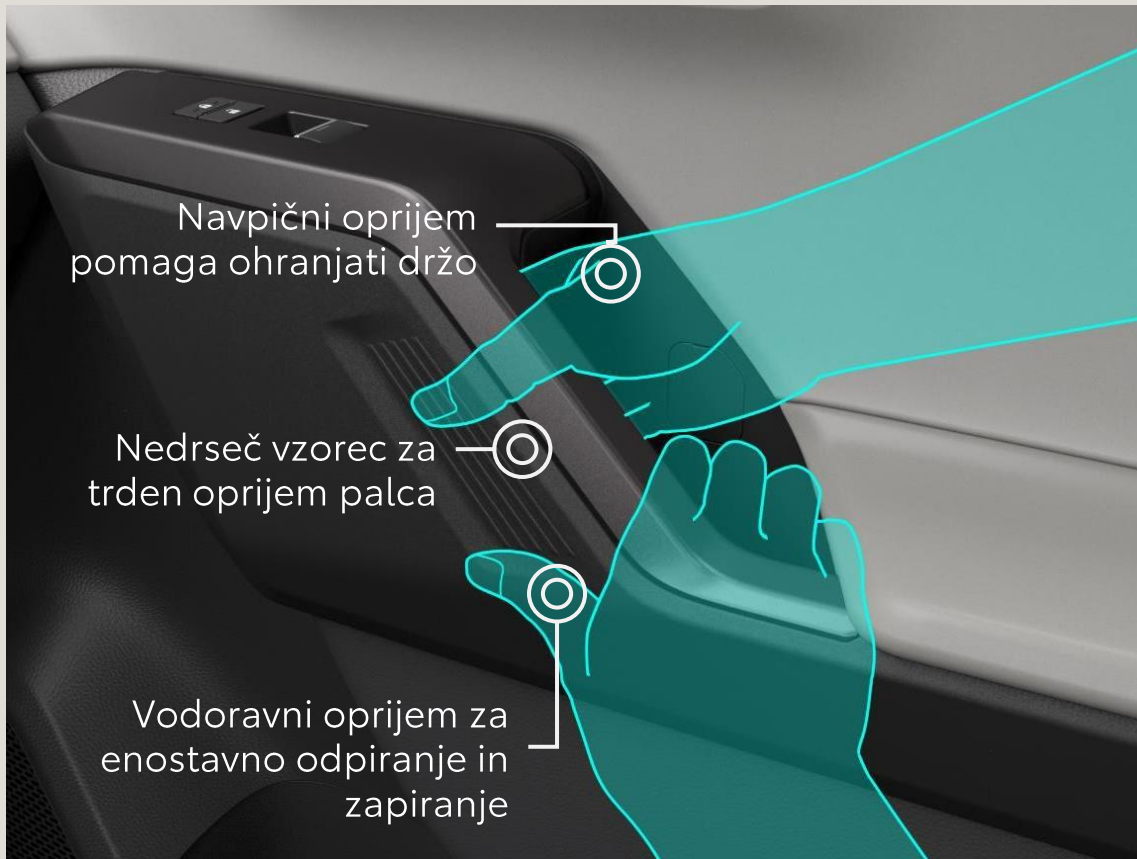

# UDOBJE IN PRIROČNOST V SUV-JU

## ZA VSE POTNIKE



Digitalni otok v sredinski konzoli  
5 vhodov USB-C  
Levi/desni odpiralni naslon za roke s pladnjem



# VISOKOKAKOVOSTNO OBLAZINJENJE



ELEKTRIČNO NAGIBNO IN DRSN  
PANORAMSKA STREHA



# ELEKTRIČNO DVIŽNO-DRSNA PANORAMSKA STREHA



316 mm  
Dolžina odprtine

688 mm širina  
odprtine



Rolo senčilna streha

# ODLIČNO IZKORIŠČEN PROSTOR



- = Enake dimenzije kot pri prejšnjem modelu
- + Več uporabnega prostora v prtljažniku
- + Lažje natovarjanje
- + Boljša vidljivost nazaj in po diagonali

■ Novi model

■ Odhajajoči model

Vse enote so v milimetrih

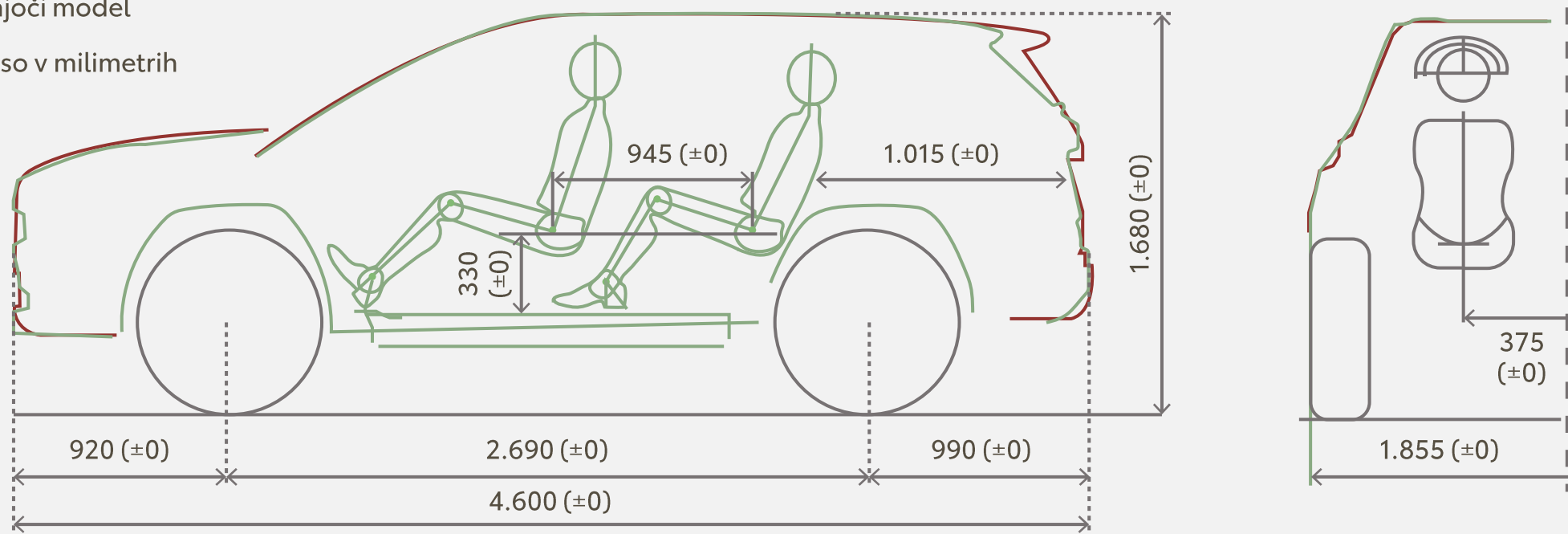



# NOVA DIGITALNA PILOTSKA KABINA

## POPOLNA INTEGRACIJA

Pogled zemljevida v kombiniranih merilnikih in upravljalnih elementih na volanu zmanjšuje gibe rok in oči



12,3-palčni kombinirani merilnik



12,9-palčni zaslon Toyota Connect



Integrirane krmilne elemente na volanu



TOYOTACONNECT

# 12.9"

## 4x HITREJE

RAM 4 GB → 16 GB

## 8-krat več notranjega polnilnika

32 GB → 256 GB

## TANJŠI ZASLON

Širina roba 13 mm → 10 mm

Debelina 18 mm → 10 mm



# 12.3"

## DIGITALNI ZASLON ZA VOZNIKA



### NOVI POGLEDI

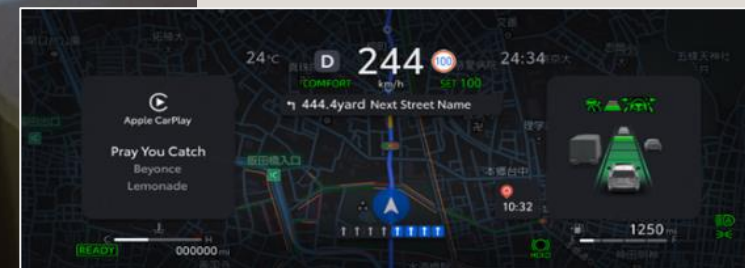

Navigacijski pogled



Pogled ADAS



EKO pogled



## KAJ JE NOVEGA...

### Bolj nagnjena površina

Za bolj intuitivno berljivost

### Daljša razdalja

Razširjena perspektiva zmanjšuje obremenitev oči

### Večji zaslon

Več kot dvakrat večji od odhajajočega modela

### Čistejša postavitev

Informacije lažje razumljive

# 23"

## HEAD-UP DISPLAY

Projicira z več prostora za prikaz informacij, kar voznikom pomaga, da ne izgubijo pogleda s ceste.



24°C

P

0

90

18:44

DAB

COMFORT

km/h

↑ 25 km Keep left on R4



Classic Hits



# TOYOTA T-MATE NOVE FUNKCIJE

## PRILAGODLJIVI TEMPOMAT (ACC)

Integrira podatke zemljevidov za prilagajanje hitrosti razmeram na cesti, kar podpira zaviranje v ovinkih in krožnih križiščih.

V načinu vožnje ECO ACC zagotavlja nežnejše pospeševanje in označuje zmanjšanje zračnega upora.





# TOYOTA T-MATE NOVE FUNKCIJE

## PANORAMSKI POGLED (PVM)

Zagotavlja nov, delno prozoren 3D-pogled in intuitivne kretnje upravljanja, podobne tabličnemu računalniku.



OPOMBA: Slika je namenjena usposabljanju



### **DOTIK**

Preklopno delovanje



### **DVOJNI DOTIK**

Vrnitev na začetni pogled



### **ZAVRTJE/POVLEC**

Zavrtitev pogleda



### **ŠTIPANJE/RAZDALJANJE**

Prilagajanje velikosti



### **VEČ POVLECOV**

Vzporedno gibanje

# NOVI PAKETI POVEZANIH STORITEV



## STANDARDNE STORITVE



MYTOYOTA



TSS4 OTA



OTA



CLOUD NAVI



GLASOVNI  
AGENT

NOVO

NOVO

NOVO

## PAMETNI DIGITALNI KLJUČ+



NOVA TEHNOLOGIJA  
VEČ KLJUČEV ZA DELJENJE

NOVO

## POVEŽI SE IN VOZI



PAMETNA  
NAVI



STORITVE NA  
DALJAVO



PRETAKANJE  
GLASBE



INTELIGENTNI  
AGENT

NOVO

## POVEŽI SE IN VARNO



SNEMALNIK  
POGONA



POMOČNIK PRI  
KRAJI AVTOMOBILA



DALJINSKA  
IMOBILIZACIJA



**RAV4**

**POGONSKI SKLOP  
NASLEDNJE GENERACIJE**

# POSODOBLJENE SPECIFIKACIJE POGONSKEGA SKLOPNIKA

## NOVI RAV4 HEV IN PHEV



Pogonski sklop	Motor	Pogonski sklop	Moč (KM)	Navor (Nm)	0-100 km/h (sekunde)	Kapaciteta baterije	Najvišja hitrost
HEV	2,5 l	Prednji pogon	183 KM	221 Nm	8,0	NA	180
		Štirikolesni pogon	191 KM	221 Nm	7,7		
PHEV	2,5 l	Prednji pogon	268 KM	227 Nm	7,5	22,7 kWh (+5,3 kWh) = Doseg do 137 km	180
		Štirikolesni pogon	304 KM	227 Nm	5,8		

**BOLJŠA ZMOGLJIVOST PHEV**



**137 km**

Kombinirani doseg WLTP FWD

**3 ure**

Polnjenje z izmeničnim tokom od 0 do 100 %  
zahvaljujoč 11 kW OBC

**30 minut**

Hitro polnjenje z enosmernim tokom 10–80 %  
pri najvišji moči 50 kW



BOLJŠA ZMOGLJIVOST PHEV



**1000 km**

Kombinirani doseg WLTP za samozavest  
na daljših potovanjih



**1.000.000 km**

Jamstva na pogonsko baterijo BEV, PHEV  
in HEV

RAV4  
RAV4  
RAV4  
RAV4



# 1.000.000 KM JAMSTVA NA BATERIJO

- POGONSKA BATERIJA NA VSEH BEV, PHEV IN HEV
- KATERI AVTOMOBILSKI PROIZVAJALEC BI LAHKO PONUDIL TAKO JAMSTVO?
- KATERI AVTOMOBILSKI PROIZVAJALEC IMA VAŠE ZAUPANJE?

TOYOTA	RAV4	10 let	1.000.000 km
VOLKSWAGEN	TIGUAN	8 let	160.000 km
VOLKSWAGEN	TAYRON	8 let	160.000 km
RENAULT	KOLEOS	8 let	160.000 km
PEUGEOT	5008	8 let	160.000 km
HYUNDAI	SANTA FE	8 let	160.000 km
ŠKODA	KODIAQ	8 let	160.000 km
KIA	SORENTO	7 let	150.000 km
MITSUBISHI	OUTLANDER	8 let	160.000 km
NISSAN	X-TRAIL	5 let	100.000 km

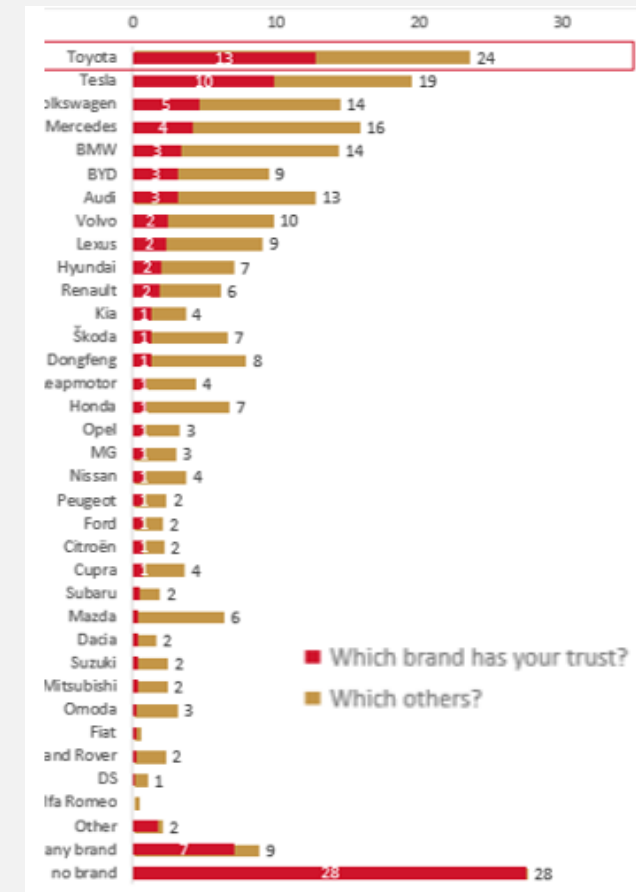

# OPTIMIZACIJA UPORABE BATERIJE

## GEOFENCING



OBVESTILO O  
VSTOPU/IZHODU IZ LEZ  
OBMOČJA

OBVESTILO O  
PRIKAZU

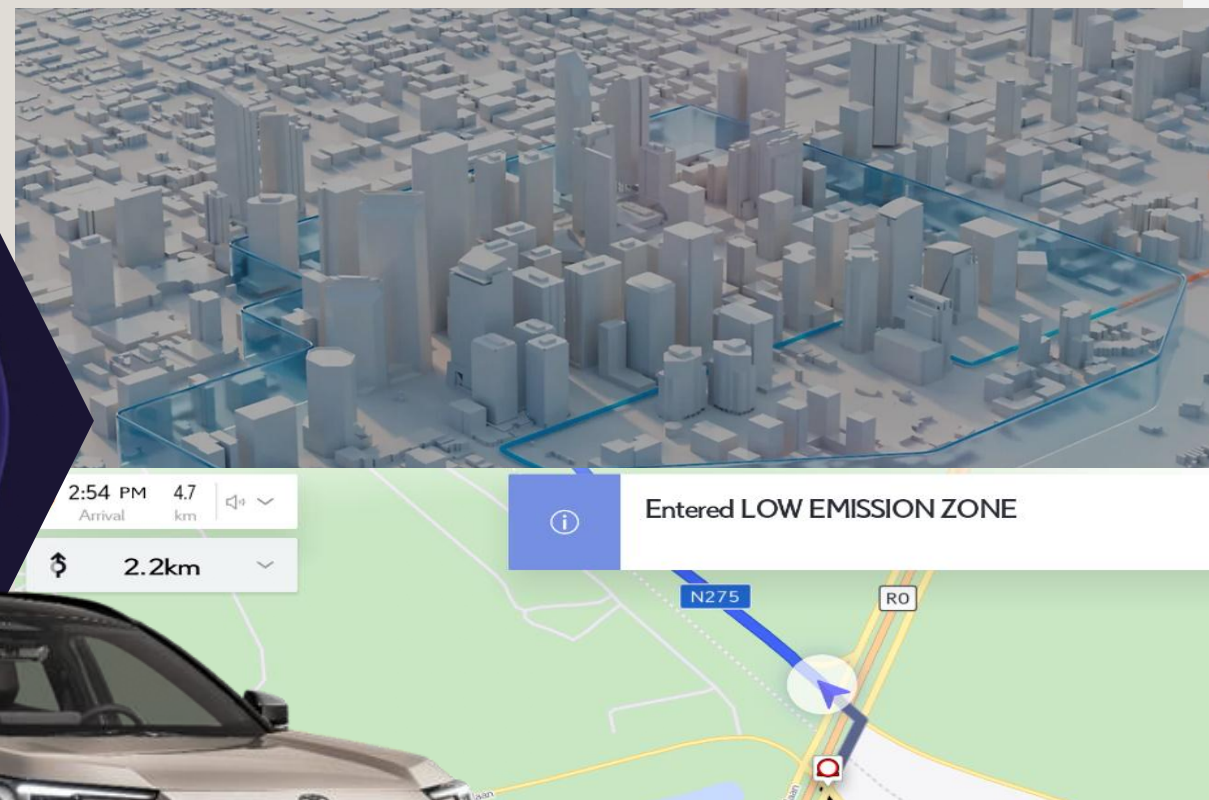

# NAJBOLJŠA VLEČNA ZMOGLJIVOST

MODELI S POGONOM NA VSA ŠTIRI  
KOLESA (HEV IN PHEV)



DO  
**2000**  
KG

NOVO

Vlečna kljuka, združljiva s  
senzorjem za električno  
odpiranje prtljažnih vrat





# SPREMENJENA PLATFORMA TNGA-K IZBOLJŠANA

Nižje težišče ob hkratnem zagotavljanju  
odmika od tal



10 % večja togost karoserije za boljše  
upravljanje in stabilnost

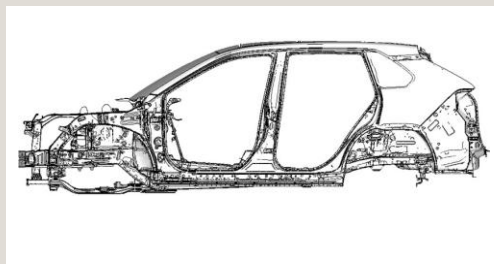

Izboljšana raven hrupa in vibracij (NVH) za  
tiho kabino na vseh cestah



Izboljšano vzmetenje in zavore

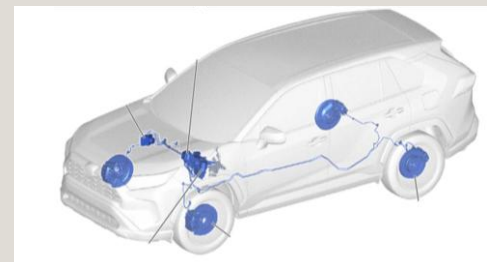
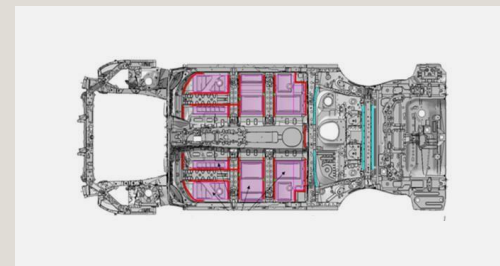
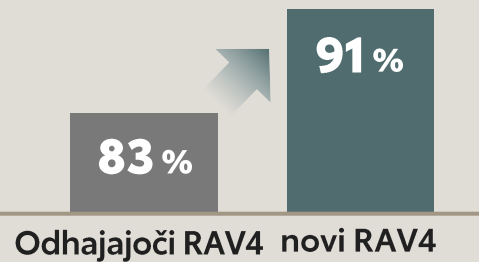
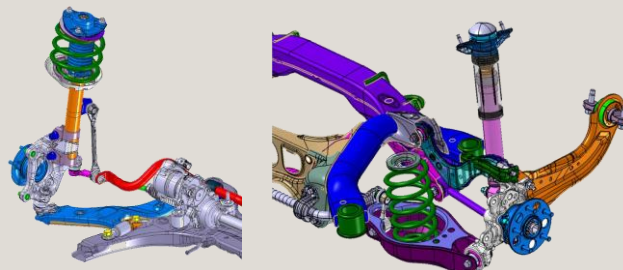

# MOČNEJŠI V VSEH POGLEDIH

## NOVA VOZNA DINAMIKA RAV4

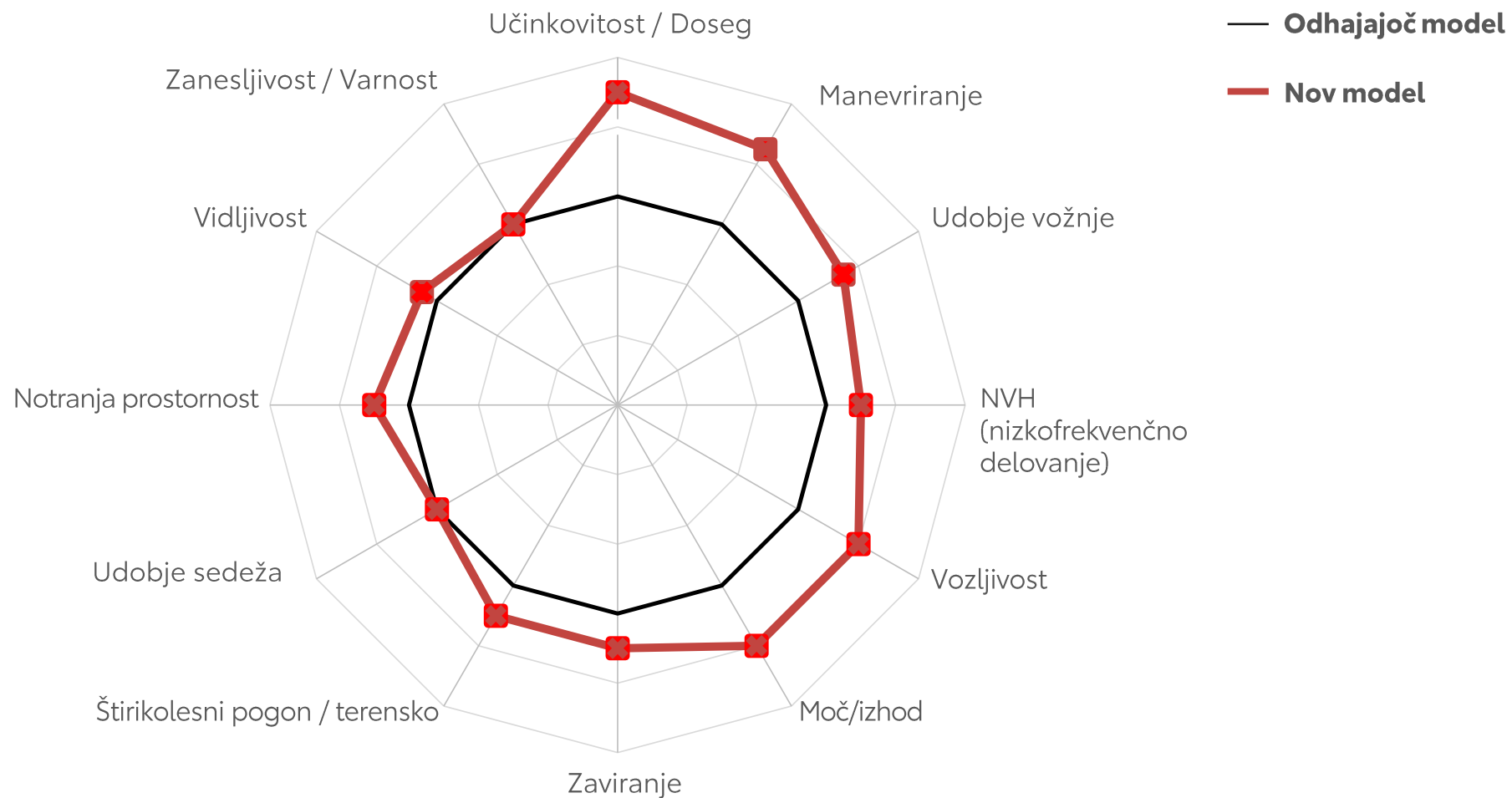



RAV4

GR SPORT, MOTOŠPORTNO  
NAVDIHNJEN



# NOVI RAV4 GR SPORT

## EDINSTVENE SPECIFIKACIJE

Lahka 20-palčna črna aluminijasta platišča Sport dizajn GR

Aluminijasti pedali zavore in plina

Športni sedeži in črna notranjost

Prenova vzmetenja in servo volana

Visokozmogljiva zasnova blažilnikov

Ojačana opora zadnjega vzmetenja

20 mm širši stična površina pnevmatike



# PRIVLAČNA IN ŠPORTNA POENOTENA MATRIČNA MASKA



+20 mm

Širša profilna plast pnevmatike za boljši oprijem in stabilnost



Mrežasta maska GR SPORT z značko GR in funkcionalnimi režami za hlajenje motorja



Ohišje meglenk z aerodinamičnimi režami

**IZRAZITA**

# AERODINAMIKA IN STABILNOST



**+12,5 mm**

Širše sprednje in zadnje obloge kolotekov



Spodnji spojler doda značaj SUV-ja in pomaga pri aerodinamiki



Značka GR SPORT

# GR SPORT



**GR SPORT**

## 20-PALČNA ALU PLATIŠČA

- ✓ Dvojna krakasta zasnova Truss s črnimi kolesnimi maticami
- ✓ 2,2 kg (na platišče) lažja, a hkrati močnejša



**ČISTA VOŽNJA**

# ARMATurna PLOŠČA, OSREDOTOČENA NA VOZNIKA

Perforiran usnjen volan z značko GR



Kolenčne blazine v konzoli zagotavljajo oporo med športno vožnjo



Športni sedeži, oblazinjeni v sintetičnem semišu z rdečimi šivi



Aluminijasti pedali in zaščita pragov GR

# ŠPORTNA BARVNA PALETA



3U5 EMOTIONALNA RDEČA 2

089 PLATINASTA BISERNO BELA

1L6 URBAN SHADE

1M6 WARM STONE

# BOLJ SOLIDEN OBČUTEK VOLANA

## UGLASITEV EPS V ŠPORTNEM NAČINU

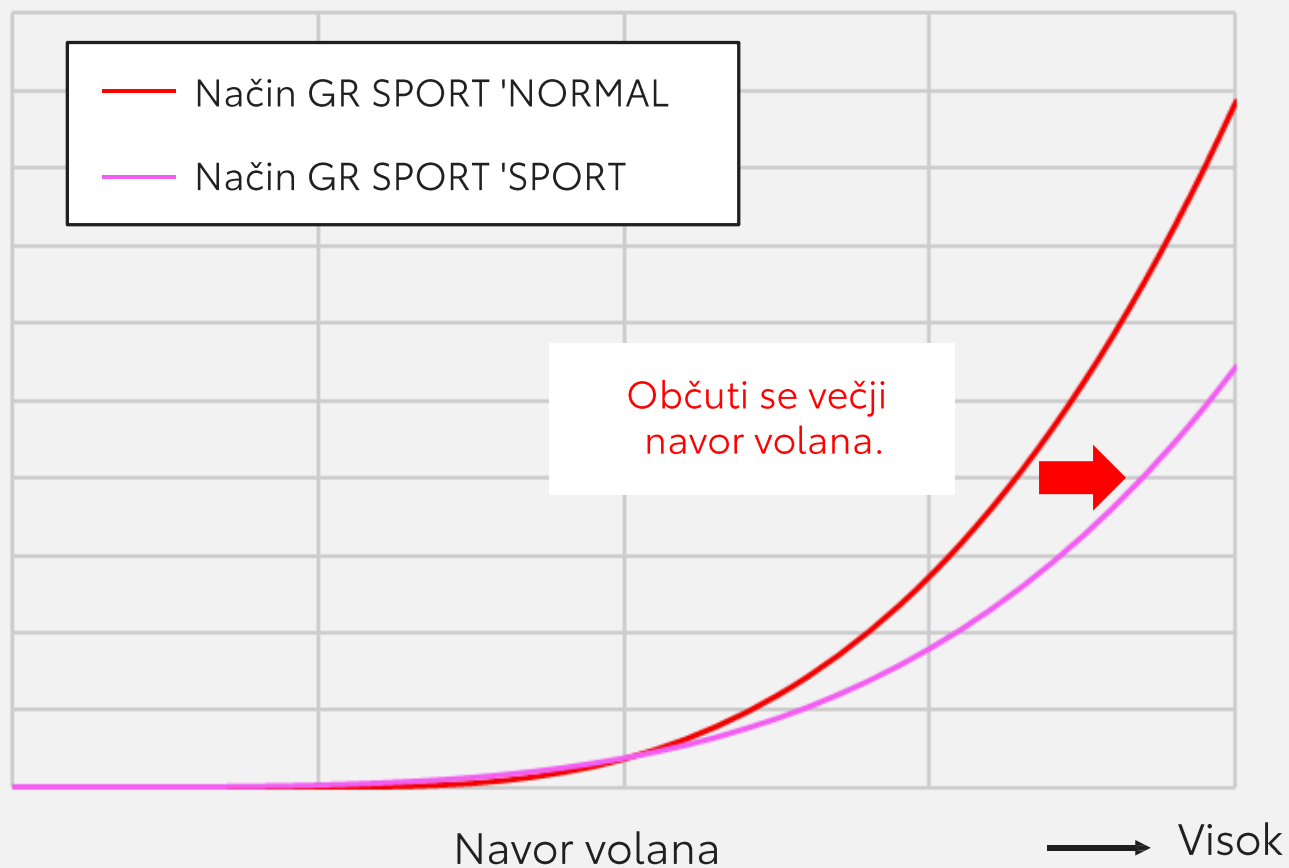

# IZBOLJŠANA VODLJIVOST

## NASTAVITEV KAROSERIJE IN PODVOZJA



Sprednji blažilnik

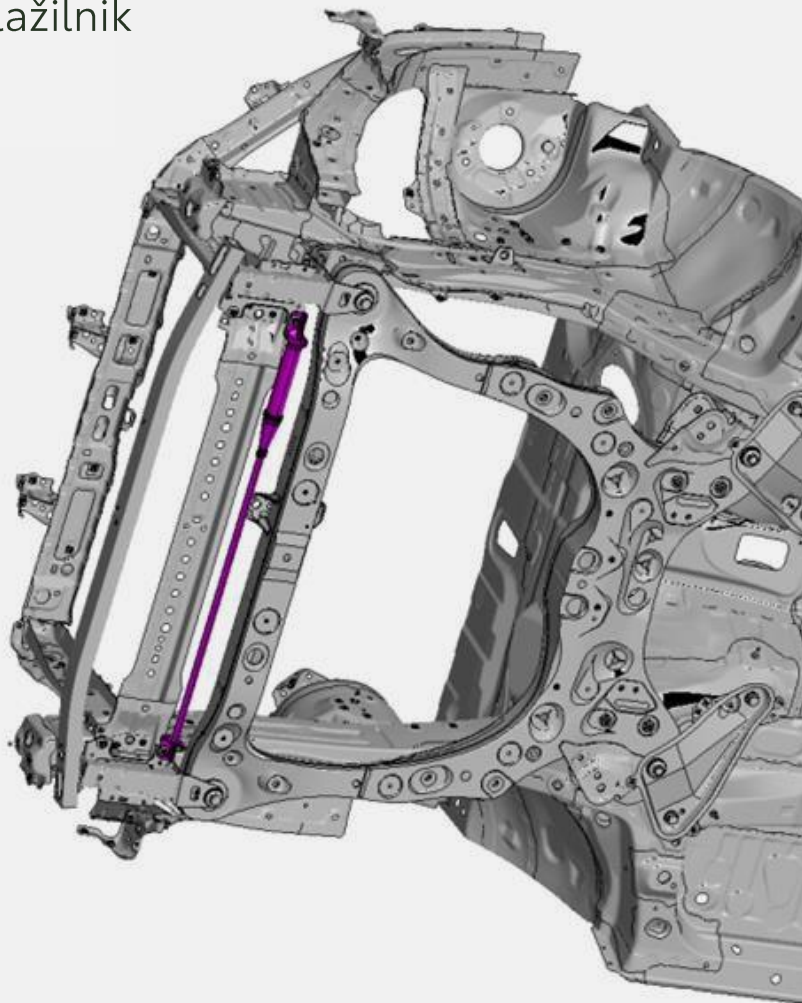

**Modeli HEV**

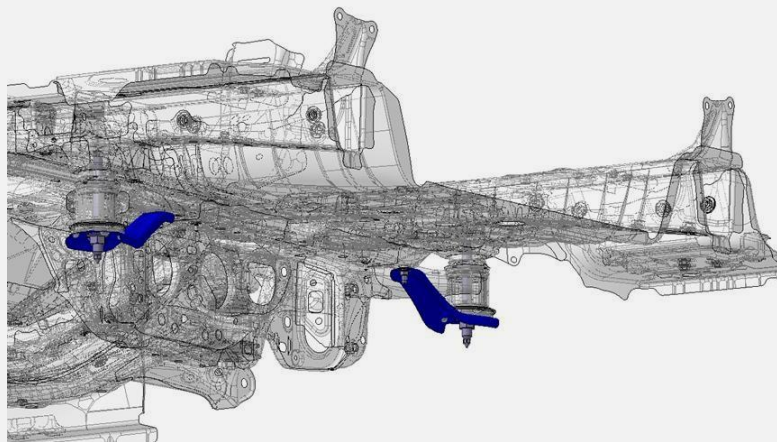

Opora zadnjega vzmetenja s povečano debelino plošče t2.0→t2.3

**Modeli PHEV**

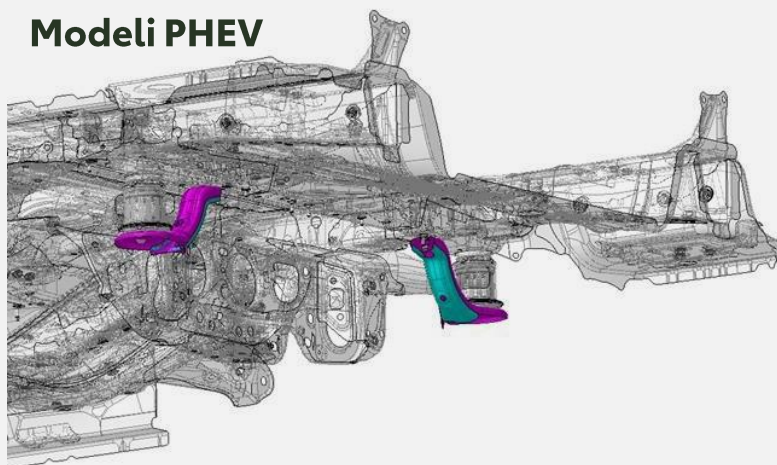

Opora zadnjega vzmetenja z dodatno oporo

# RAVNA IN UMIRJENA VOŽNJA

## NAMENSKI AMORTIZERJI

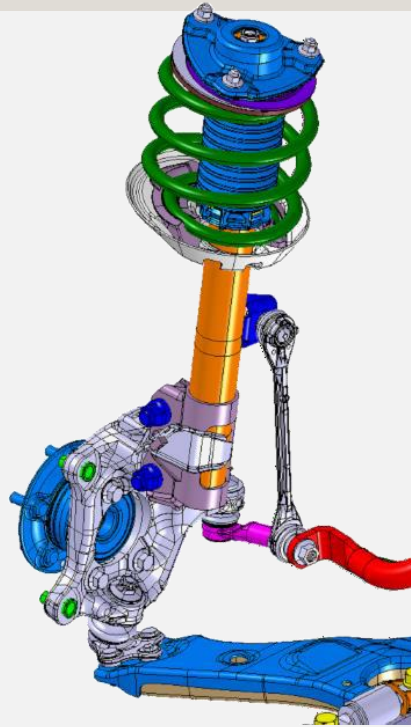

SPREDNJE VZMETENJE

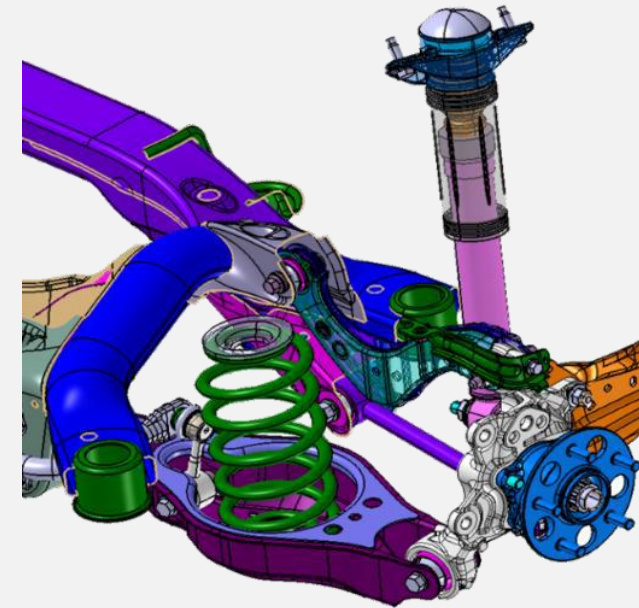

ZADNJE VZMETENJE

	Core	GR SPORT
Trdnost vzmeti (N/mm)	32	40
Frekvenca vzmeti (Hz)	1,26	1,38

	Core	GR SPORT
Trdnost vzmeti (N/mm)	50	62
Frekvenca vzmeti (Hz)	1,41	1,52



# »SAMOZAVESTEN IN NARAVEN« NAJBOLJ VOZNIŠKO USMERJEN RAV4

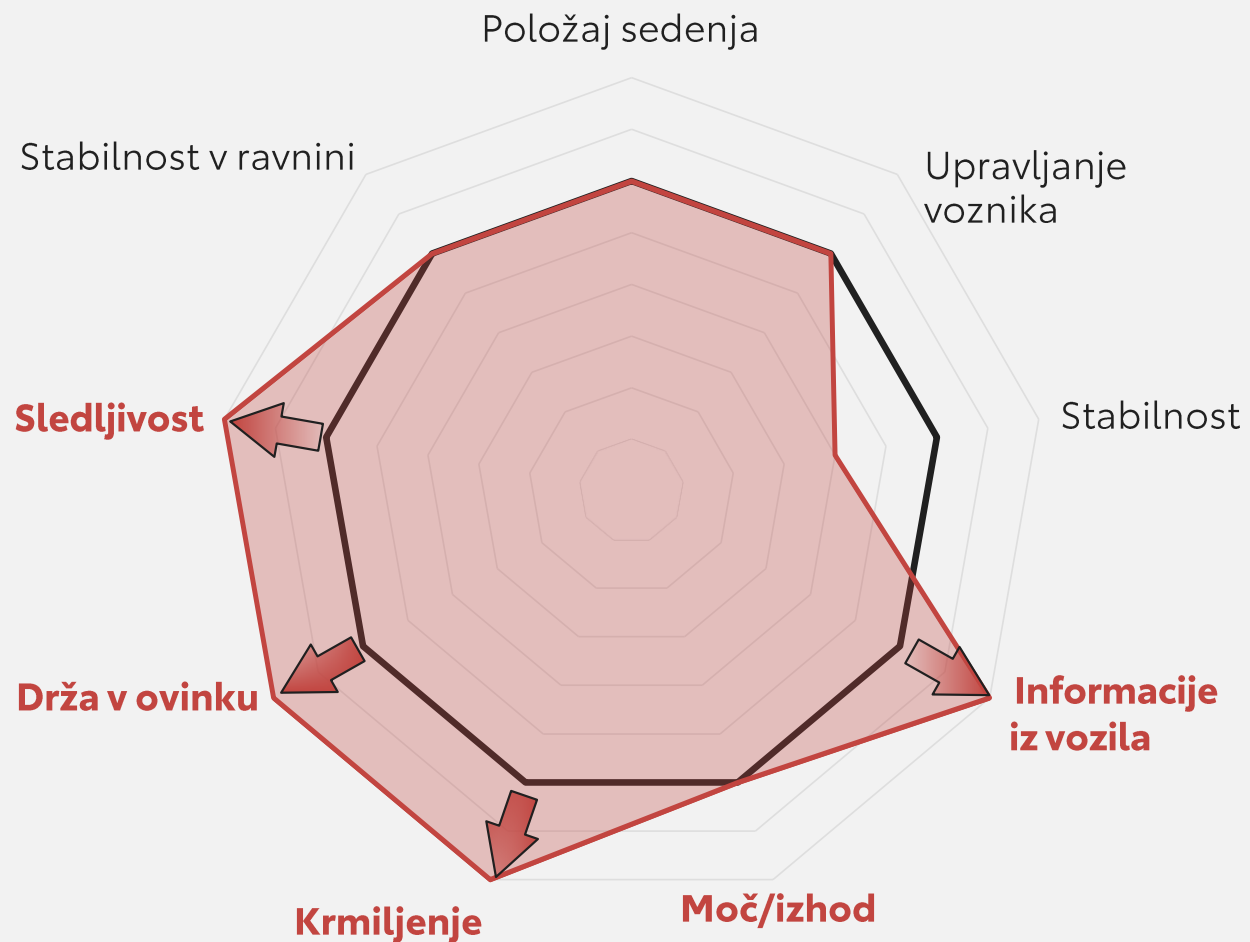

Osnovni model

GR SPORT



NIVO OPREME	MOTOR	MENJALNIK POGON	PROSTORNINA	MOČ MOTORJA	IZPUSTI CO <sub>2</sub> (g/km)	CENA	AKCIJSKA CENA
ELEGANT	2.5 TNGA HEV	CVT (4x2)	2.487 cm <sup>3</sup>	136 kW / 183 KM	112	38.500 €	-
STYLE	2.5 TNGA HEV	CVT (4x2)	2.487 cm <sup>3</sup>	136 kW / 183 KM	117 - 118	46.750 €	46.250 €
PREMIUM	2.5 TNGA HEV	CVT (4x2)	2.487 cm <sup>3</sup>	136 kW / 183 KM	118	51.750 €	51.250 €
ELEGANT	2.5 TNGA HEV	CVT (4x4)	2.487 cm <sup>3</sup>	143 kW / 192 KM	121	41.750 €	-
STYLE	2.5 TNGA HEV	CVT (4x4)	2.487 cm <sup>3</sup>	143 kW / 192 KM	127 - 128	49.000 €	48.500 €
PREMIUM	2.5 TNGA HEV	CVT (4x4)	2.487 cm <sup>3</sup>	143 kW / 192 KM	127 - 128	54.000 €	53.500 €
GR-SPORT	2.5 TNGA HEV	CVT (4x4)	2.487 cm <sup>3</sup>	143 kW / 192 KM	129	53.500 €	53.000 €

Akcijski popust: 500 €\*

Bon za Toyota Financiranje:\*

Redno: 300 €

Easy: 750 €

Bon za nakup zimskih kompletov: 500 €

Bon staro za novo: 500 €\*

Na nivoju opremem Style brezplačen paket Tech

V ceno vozila je vključeno obvezno in kasko zavarovanje\*

Paket Tech

- Stranski kameri za Panoramski pogled na vzratnih ogledalih
- Barvni prikazovalnik podatkov na vetrobranskem steklu (HUD)
- Panoramski pogled s 3D učinkom (omogoča 360<sup>0</sup> pogled okoli vozila ter pogled na vozilo in okolico iz ptičje perspektive s pomočjo 4 kamer)

\*ne velja za nivo opreme Elegant in Elegant Winter



VPRAŠANJA

# RAV4 GR SPORT TESTNE VOŽNJE



**VSAKDANJE  
CESTE**



**MESTO**

**TERENSKA  
VOŽNJA**



**MAKEDAM**



# RAV4

## TESTNE VOŽNJE

- Krog cca 30min
- 2 terenska dela
- Omejitve hitrosti



SKENIRAJ – 1. DEL



SKENIRAJ – 2. DEL

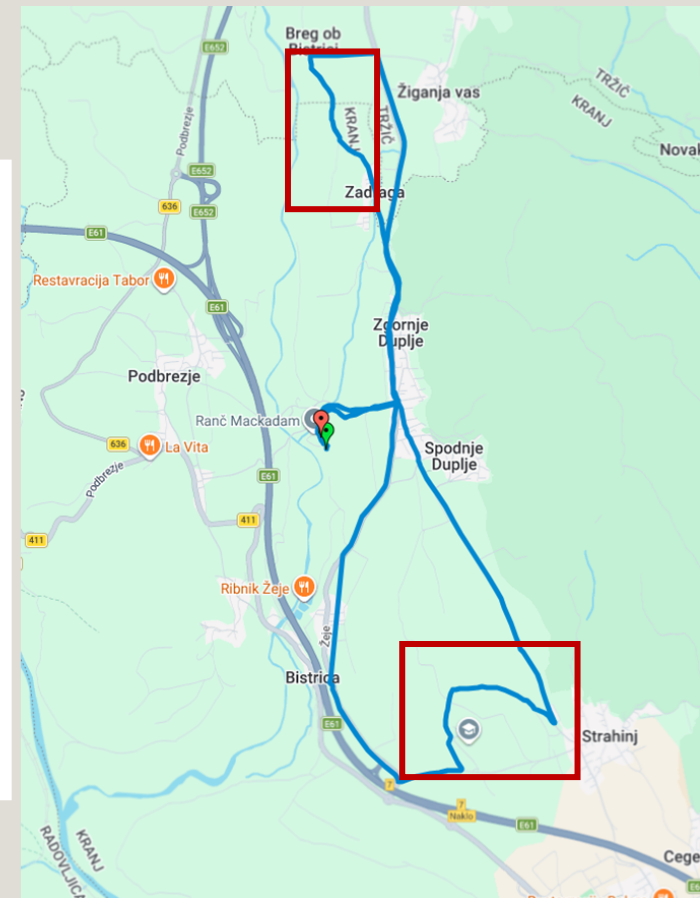





**RAV4**

**HVALA ZA POZORNOST**